

ELIMINATOR[®]

LIGHTING

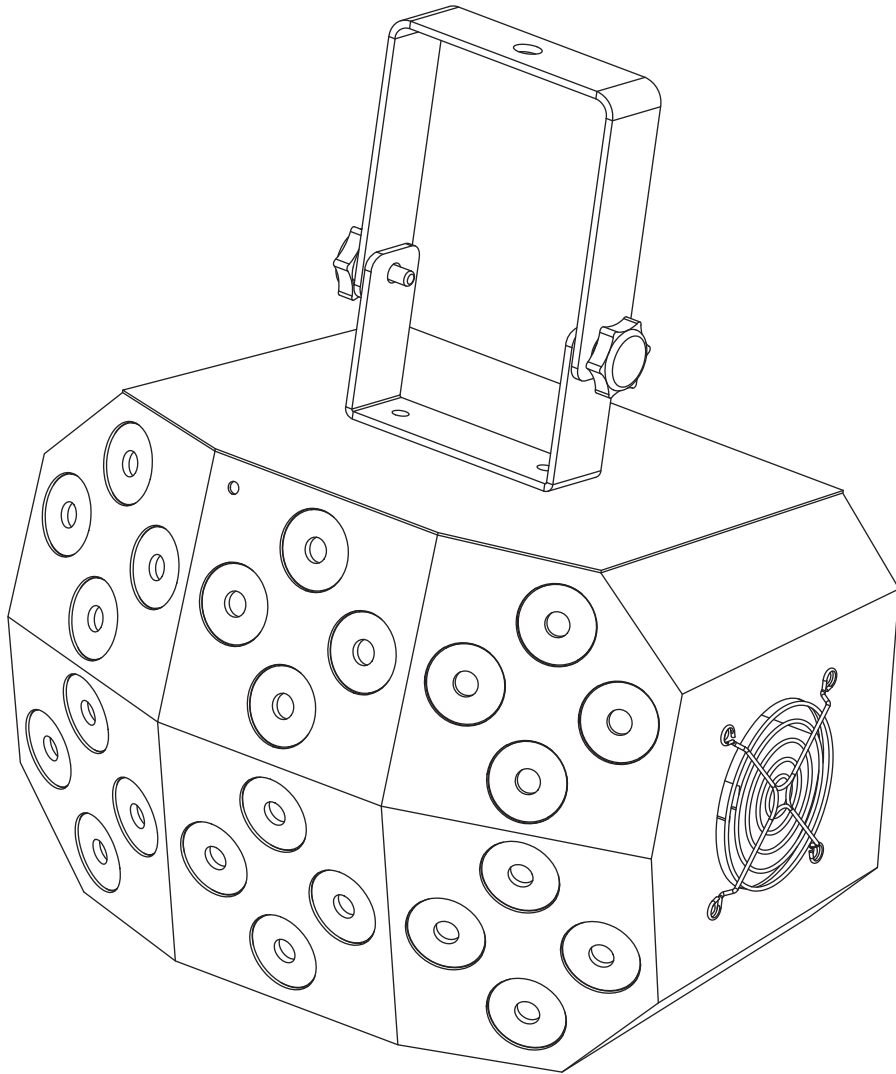

MEGA WASH 24

User Manual

©2023 **Eliminator Lighting** all rights reserved. Information, specifications, diagrams, images, and instructions herein are subject to change without notice. Eliminator logo and identifying product names and numbers herein are trademarks of Eliminator Lighting. Copyright protection claimed includes all forms and matters of copyrightable materials and information now allowed by statutory or judicial law or hereinafter granted. Product names used in this document may be trademarks or registered trademarks of their respective companies and are hereby acknowledged. All non-Eliminator brands and product names are trademarks or registered trademarks of their respective companies.

Eliminator Lighting and all affiliated companies hereby disclaim any and all liabilities for property, equipment, building, and electrical damages, injuries to any persons, and direct or indirect economic loss associated with the use or reliance of any information contained within this document, and/or as a result of the improper, unsafe, insufficient and negligent assembly, installation, rigging, and operation of this product.

Eliminator Lighting

6122 S. Eastern Ave. Los Angeles, CA. 90040
323-582-2650 | Fax 323-532-2941 | www.adj.com | info@adj.com

ADJ SUPPLY Europe B.V

Junostraat 2 6468 EW Kerkrade, The Netherlands
+31 (0)45 546 85 00 | Fax +31 45 546 85 99
www.adj.eu | info@adj.eu

ADJ PRODUCTS GROUP Mexico

AV Santa Ana 30 Parque Industrial Lerma, Lerma, Mexico 52000
+52 (728) 282-7070

DOCUMENT VERSION



Due to additional product features and/or enhancements, an updated version of this document may be available online. Please check www.adj.com for the latest revision/update of this manual before beginning installation and/or programming.

Date	Document Version	Software Version >	DMX Channel Mode	Notes
12/11/23	1.0	02	3 / 6 / 10 / 40 Ch	Initial release

CONTENTS

General Information	4
Limited Warranty (USA Only)	5
Safety Guidelines	6
Overview	9
Installation Guidelines	10
Control Panel	12
System Menu	13
Remote Operation	14
Primary-Secondary Setup Multi Unit Power Linking	15
DMX Setup	16
DMX Traits	19
Cleaning and Maintenance	22
Specifications	23
Dimensional Drawings	24

GENERAL INFORMATION

INTRODUCTION

Please read and understand all instructions in this manual carefully and thoroughly before attempting to operate this device. These instructions contain important safety and use information.

UNPACKING

This device has been thoroughly tested and has been shipped in perfect operating condition. Carefully check the shipping carton for damage that may have occurred during shipping. If the carton appears to be damaged, carefully inspect the device for damage and be sure that all accessories necessary to operate the device have arrived intact. In the event that damage has been found or parts are missing, please contact our customer support team for further instructions. Please do not return this device to your dealer without first contacting customer support at the number listed below. Please do not discard the shipping carton in the trash. Please recycle whenever possible.

WARRANTY RETURNS

All returned service items, whether under warranty or not, must be freight pre-paid and accompanied by a return authorization (R.A.) number. The R.A. number must be clearly written on the outside of the return package. A brief description of the problem as well as the R.A. number must also be written down on a piece of paper and included in the shipping container. If the unit is under warranty, you must provide a copy of your proof of purchase invoice. Items returned without an R.A. number clearly marked on the outside of the package will be refused and returned at customer's expense. You may obtain an R.A. number by contacting customer support.

INCLUDED ITEMS

- Power Cable (x1)
- IR Controller (x1)

Warning! To prevent or reduce the risk of electrical shock or fire, do not expose this unit to rain or moisture.

Caution! There are no user serviceable parts inside this unit. Do not attempt any repairs yourself, as doing so will void your manufacturer's warranty. In the event that your unit requires service, please contact Elimi-

LIMITED WARRANTY (USA ONLY)

- A. Eliminator Lighting, an ADJ Products, LLC brand, hereby warrants, to the original purchaser, Eliminator Lighting products to be free of manufacturing defects in material and workmanship for a prescribed period from the date of purchase (see specific warranty period on reverse). This warranty shall be valid only if the product is purchased within the United States of America, including possessions and territories. It is the owner's responsibility to establish the date and place of purchase by acceptable evidence, at the time service is sought.
- B. For warranty service, you must obtain a Return Authorization number (RA#) before sending back the product—please contact ADJ Products, LLC Service Department at 800-322-6337. Send the product only to the Eliminator Lighting factory. All shipping charges must be pre-paid. If the requested repairs or service (including parts replacement) are within the terms of this warranty, Eliminator Lighting will pay return shipping charges only to a designated point within the United States. If the entire instrument is sent, it must be shipped in its original package. No accessories should be shipped with the product. If any accessories are shipped with the product, Eliminator Lighting shall have no liability whatsoever for loss of or damage to any such accessories, or for the safe return thereof.
- C. This warranty is void if the serial number has been altered or removed; if the product is modified in any manner which Eliminator Lighting concludes, after inspection, affects the reliability of the product, if the product has been repaired or service by anyone other than ADJ Products, LLC factory unless prior written authorization was issued to purchaser by Eliminator Lighting; if the product is damaged because not properly maintained as set forth in the instruction manual.
- D. This is not a service contract, and this warranty does not include maintenance, cleaning or periodic check up. During the period specified above, Eliminator Lighting will replace defective parts at its expense with new or refurbished parts, and will absorb all expenses for warranty service and repair labor by reason of defects in material or workmanship. The sole responsibility of Eliminator Lighting under this warranty shall be limited to the repair of the product, or replacement thereof, including parts, at the sole discretion of Eliminator Lighting. All products covered by this warranty were manufactured after August 15, 2012, and bear identifying marks to that effect.
- E. Eliminator Lighting reserves the right to make changes in design and/or improvements upon its products without any obligation to include these changes in any products theretofore manufactured.
- F. No warranty, whether expressed or implied, is given or made with respect to any accessory supplied with products described above. Except to the extent prohibited by applicable law, all implied warranties made by Eliminator Lighting in connection with this product, including warranties of merchantability or fitness, are limited in duration to the warranty period set forth above. And no warranties, whether expressed or implied, including warranties of merchantability or fitness, shall apply to this product after said period has expired. The consumer's and/or Dealer's sole remedy shall be such repair or replacement as is expressly provided above; and under no circumstances shall Eliminator Lighting be liable for any loss or damage, direct or consequential, arising out of the use of, or inability to use, this product.
- G. This warranty is the only written warranty applicable to Eliminator Lighting products and supersedes all prior warranties and written descriptions of warranty terms and conditions heretofore published.

MANUFACTURER'S LIMITED WARRANTY PERIODS

- **Non L.E.D. Eliminator Lighting products** = 1-year (365 days) Limited Warranty (Such as: Special Effect Lighting, Intelligent Lighting, UV lighting, Strobes, Fog Machines, Bubble Machines, Mirror Balls, Par Cans, Trussing, Lighting Stands etc., excluding lamps)
- **L.E.D. Eliminator Lighting Products** = 2-year (730 days) Limited Warranty (excluding batteries which have a 180 day limited warranty). Note: 2 Year Warranty only applies to purchases within the United States.
- **Eliminator Laser Products** = 1 Year (365 Days) Limited Warranty (excluding laser diodes which have a 6 month limited warranty)

SAFETY GUIDELINES

To guarantee a smooth operation, it is important to follow all instructions and guidelines in this manual. Eliminator Lighting is not responsible for injury and/or damages resulting from the misuse of this fixture due to the disregard of the information printed in this manual. Only qualified and/or certified personnel should perform installation of this fixture and only the original rigging parts included with this fixture should be used for installation. Any modifications to the fixture and/or the included mounting hardware will void the original manufacturer's warranty and increase the risk of damage and/or personal injury.



PROTECTION CLASS 1 - FIXTURE MUST BE PROPERLY GROUNDED



THERE ARE NO USER SERVICEABLE PARTS INSIDE THIS UNIT. DO NOT ATTEMPT ANY REPAIRS YOURSELF, AS DOING SO WILL VOID YOUR MANUFACTURER'S WARRANTY. DAMAGES RESULTING FROM MODIFICATIONS TO THIS FIXTURE AND/OR THE DISREGARD OF SAFETY INSTRUCTIONS AND GUIDELINES IN THIS MANUAL VOID THE MANUFACTURER'S WARRANTY AND ARE NOT SUBJECT TO ANY WARRANTY CLAIMS AND/OR REPAIRS.



**DO NOT PLUG FIXTURE INTO A DIMMER PACK!
NEVER OPEN THIS FIXTURE WHILE IN USE!
UNPLUG POWER BEFORE SERVICING FIXTURE!
NEVER TOUCH FIXTURE DURING OPERATION AS IT MAY BE HOT!
KEEP FLAMMABLE MATERIALS AWAY FROM FIXTURE!**



**INDOOR / DRY LOCATIONS USE ONLY!
DO NOT EXPOSE TO RAIN AND/OR MOISTURE!**

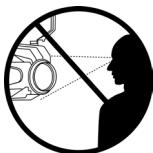

NEVER LOOK DIRECTLY INTO THE LIGHT SOURCE! RETINA INJURY RISK - MAY INDUCE BLINDNESS! SENSITIVE PERSONS MAY SUFFER AN EPILEPTIC SHOCK!

SAFETY GUIDELINES

- *This unit may “pop” the fuse if the maximum allotted load of 5 amps is reached or exceeded.*
- To reduce the risk of electrical shock or fire, do not expose this unit to rain or moisture.
- Do not spill water or other liquids into or on to your unit.
- Do not attempt to remove or break off the ground prong from the electrical cord. This prong is used to reduce the risk of electrical shock and fire in the event of an internal short.
- Do not attempt to operate this unit if the power cord is frayed or broken.
- Disconnect from main power before making any type of connection.
- Do not remove the cover for any reason. There are no user serviceable parts inside.
- Always be sure to mount this unit in an area that will allow proper ventilation. Allow about 6” (15cm) between this device and a wall.
- Do not attempt to operate this unit if it has been damaged in any way.
- This unit is intended for indoor use only. Use of this product outdoors voids all warranties.
- During long periods of non-use, disconnect the unit’s main power.
- Always mount this unit in safe and stable matter.
- Power cords should be routed so they are not likely to be walked on, pinched by items placed upon or against them.
- Cleaning - The fixture should be cleaned only as recommended by the manufacturer. See the **Maintenance Guidelines** section of this manual for cleaning details.
- Heat - The appliance should be situated away from heat sources such as radiators, heat registers, stoves, or other appliances (including amplifiers) that produce heat.
- The fixture should be serviced by qualified service personnel when:
 - A. The power-supply cord or the plug has been damaged.
 - B. Objects have fallen onto, or liquid has been spilled into, the unit.
 - C. The unit has been exposed to rain or water.
 - D. The unit does not appear to operate normally or exhibits a marked change in performance.

SAFETY GUIDELINES



HIGH INTENSITY ULTRAVIOLET LIGHT

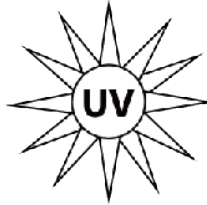

**AVOID DIRECT EYE & SKIN EXPOSURE.
WEAR PROPER EYE & SKIN PROTECTION.
SEE MANUAL FOR SAFETY INSTRUCTIONS.**

RISK GROUP 3 - RISK OF EXPOSURE TO ULTRAVIOLET UV RADIATION!

FIXTURE EMITS HIGH INTENSITY WAVELENGTH OF ULTRAVIOLET UV LIGHT FROM THE UV COLOR FILTER.

WEAR PROPER EYE AND SKIN PROTECTION. AVOID PROLONGED PERIODS OF EXPOSURE TO UV COLOR FILTER.

AVOID WEARING WHITE COLOR CLOTHING AND/OR USING UV PAINTS ON SKIN. AVOID DIRECT EYE AND/OR SKIN EXPOSURE AT DISTANCES LESS THAN 11 feet (3.3m).

DO NOT OPERATE FIXTURE WITH DAMAGED/MISSING EXTERNAL COVERS.

DO NOT LOOK DIRECTLY INTO THE UV LIGHT AND/OR VIEW UV LIGHT DIRECTLY WITH OPTICAL INSTRUMENTS THAT MAY CONCENTRATE THE LIGHT/RADIATION OUTPUT.

INDIVIDUALS SUFFERING FROM A RANGE OF EYE CONDITIONS, SUNLIGHT EXPOSURE DISORDERS, OR INDIVIDUALS USING PHOTSENSITIVE MEDICATION, MAY EXPERIENCE DISCOMFORT IF EXPOSED TO THE ULTRAVIOLET UV LIGHT EMITTED FROM THE UV LED.

OVERVIEW

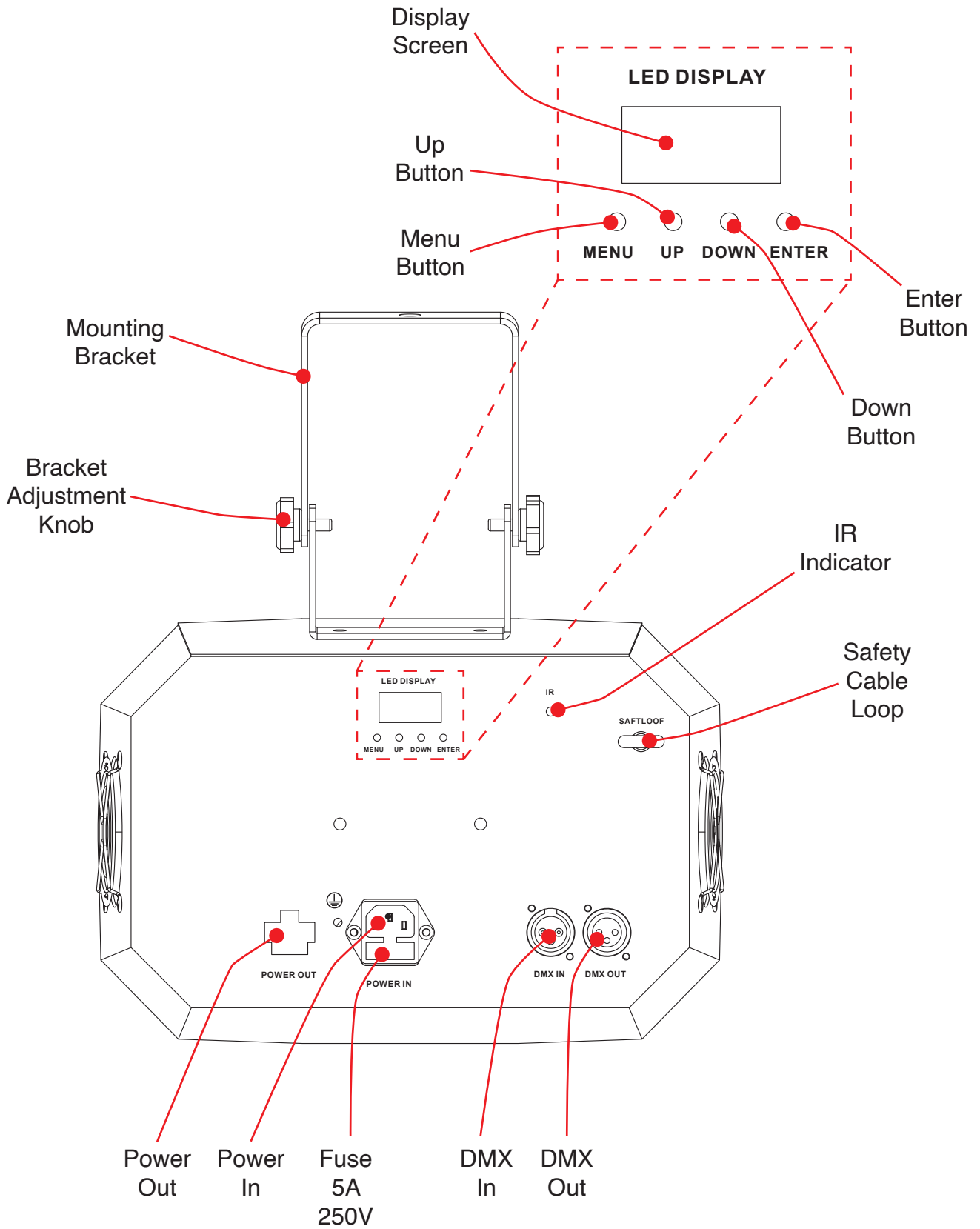

INSTALLATION GUIDELINES



ELECTRICAL CONNECTIONS

A qualified electrician should be used for all electrical connections and/or installations.



FLAMMABLE MATERIAL WARNING

Keep fixture at least 7.9in. (0.2m) away from any flammable materials, decorations, pyrotechnics, etc.



MINIMUM DISTANCE TO OBJECTS/SURFACES IS 40 FEET (12 METERS)



AMBIENT OPERATING TEMPERATURE RANGE IS -4°F TO 104°F. (-20°C TO 40°C)

DO NOT INSTALL THE FIXTURE IF YOU ARE NOT QUALIFIED TO DO SO!

Fixture **MUST** be installed following all local, national, and country commercial electrical and construction codes and regulations. Before rigging/mounting the fixture to any metal truss/structure or placing the fixture on any surface, a professional equipment installer **MUST** be consulted to determine if the metal truss/structure or surface is properly certified to safely hold the combined weight of the fixture, clamps, cables, and accessories.

Overhead fixture installation must always be secured with a secondary safety attachment, such as an appropriately rated safety cable that meets all local, national, and country codes and regulations.

Fixture ambient operating temperature range is **-4°F to 104°F. (-20°C to 40°C)** Do not use this fixture when ambient temperature falls outside this temperature range.

Fixture should be installed away from walking paths, seating areas, or areas where unauthorized personnel might reach the fixture by hand.

NEVER stand directly below the fixture when rigging, removing, or servicing.

Allow approximately 15-minutes for the fixture to cool down before servicing.

INSTALLATION GUIDELINES

CLAMP INSTALLATION

This fixture features a mounting clamp attachment point, which is located on the mounting yoke, as well as a safety cable rigging point, located on the rear face of the unit near the display screen (see the illustration below). When mounting the fixture to a truss or any other suspended or overhead installation, be sure to secure an appropriately rated clamp (not included) to the mounting yoke by inserting a bolt of the appropriate size and weight rating through the clamp hole and the mounting yoke, then secure in place using a matching washer and nut. Always attach a separate SAFETY CABLE of the appropriate safety rating to the safety cable rigging point.

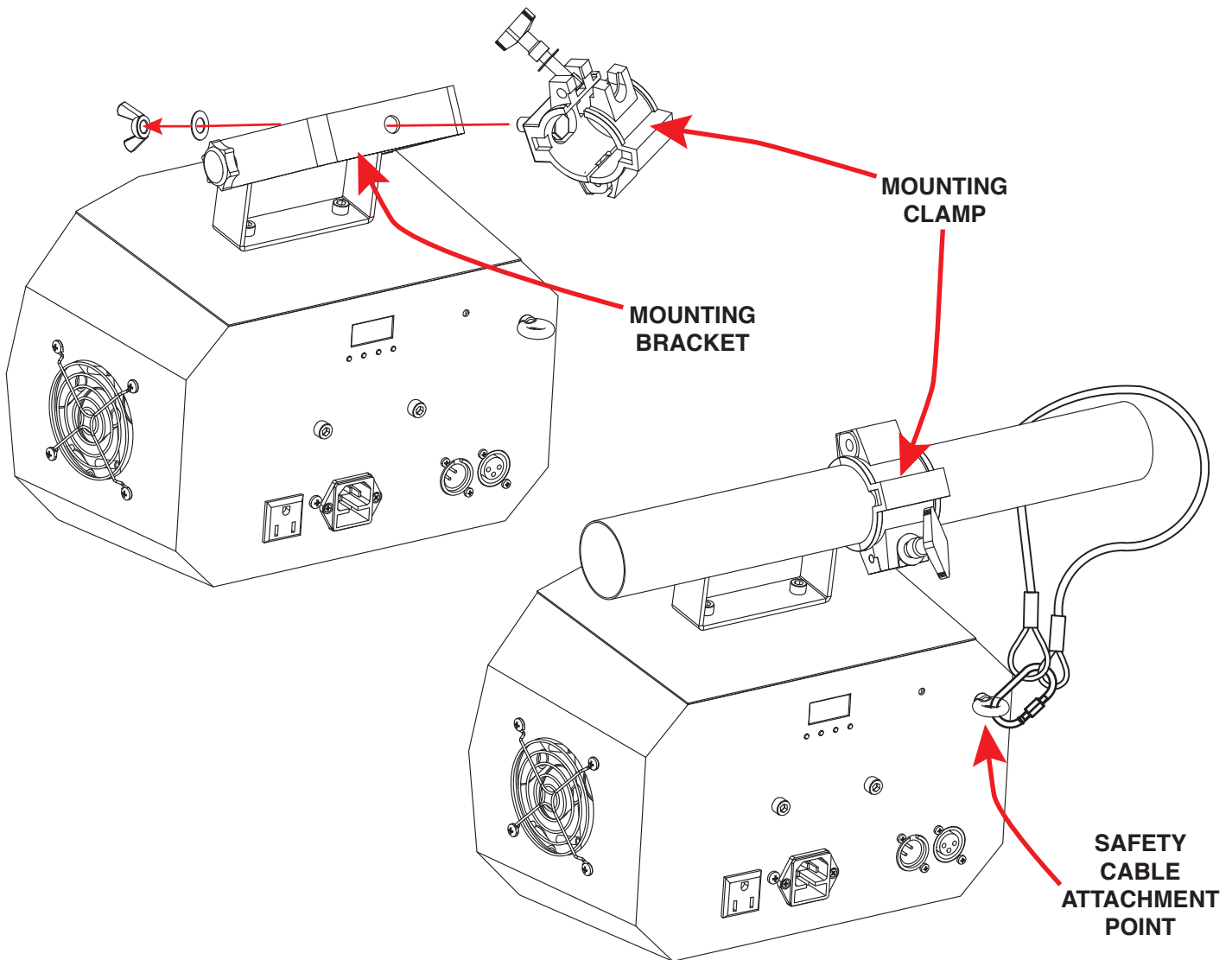

ALWAYS ATTACH A SAFETY CABLE WHENEVER INSTALLING THIS FIXTURE IN A SUSPENDED ENVIRONMENT TO ENSURE THE FIXTURE WILL NOT FALL IF THE CLAMP FAILS.

RIGGING

Overhead rigging requires extensive experience, including but not limited to: calculating working load limits, understanding the installation material being used, and periodic safety inspection of all installation material and the fixture itself. If you lack these qualifications, do not attempt to perform the installation yourself. Improper installation can result in bodily injury.

CONTROL PANEL

The device includes an easy to navigate system menu that can be accessed via a set of control buttons located on the back of the device below the digital display.

MODE: Press to cycle through main menu options (Auto, Sound, Sec, DMX).

ENTER: Press to confirm selection and open up the option sub-menu, if applicable.

UP/DOWN: Press to scroll through menu or sub-menu options.

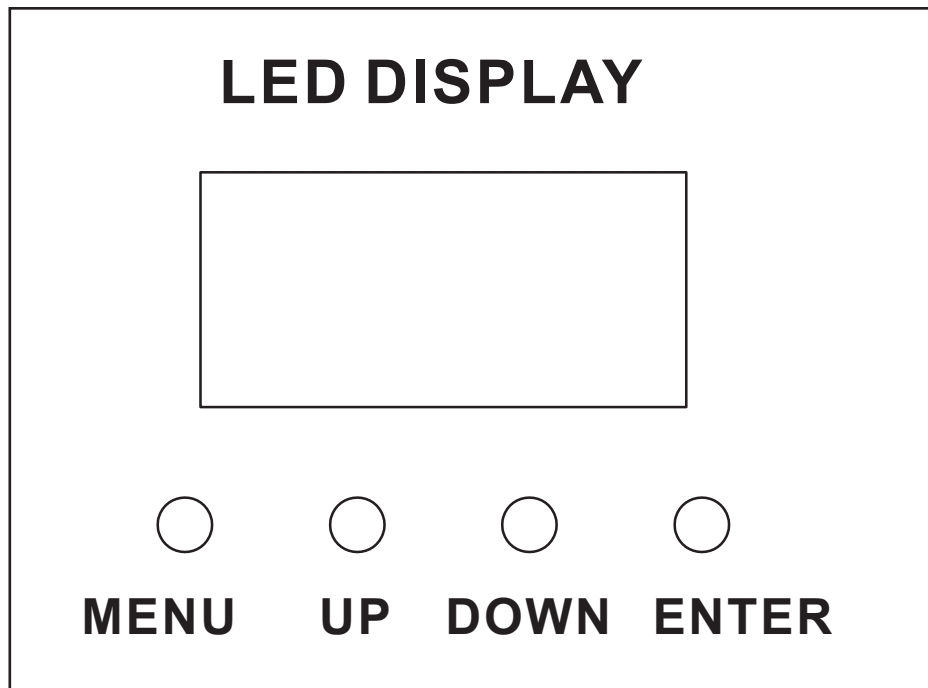

SYSTEM MENU

Addr	A001 - A512	Set DMX address
ChNd	3Ch	3-channel DMX mode
	6Ch	6-channel DMX mode
	10Ch	10-channel DMX mode
	40Ch	40-channel DMX mode
Colo	CL01 - CL22	Color selection
Auto	Au01 - Au18	Auto program mode
SPed	S001 - S100	Auto program mode speed
Soud	Su01 - Su12	Sound control mode
SenS	u001 - u100	Sound control mode sensitivity
diM	L001 - L100	Master dimming, 1% to 100%
Cust	r000 - r255	Red color dimming, 0% to 100%
	g000 - g255	Green color dimming, 0% to 100%
	b000 - b255	Blue color dimming, 0% to 100%
	U000 - U255	White color dimming, 0% to 100%
	y000 - y255	Amber color dimming, 0% to 100%
	P000 - P255	UV color dimming, 0% to 100%
	F000 - F255	Strobe speed, slow to fast
Ir	ON	IR control enabled
	OFF	IR control disabled

REMOTE OPERATION

The unit can only be controlled when it has been set to **Primary mode**. The unit will **NOT** respond to commands when operating in **Secondary mode**.

- **On:** Fixture turns on and reverts to the last running state
- **Off:** Fixture goes into stand by mode in a blackout state.
- **Color:** Activates color mode. Select a static color using the colored keys. The intensity for the set color can then be adjusted with the + / - buttons. Selectable colors are red, green, blue, orange, lime green, pink, amber, cyan, magenta, yellow, purple, and white.
- **Auto:** Activate auto program mode. Press this button, then use the + and - buttons to cycle through the programs until you find your desired program. Then press the Speed button, and use the + and - buttons to adjust the program speed.
- **Sound:** Runs through the sound active mode, in which the unit responds to microphone inputs. Press this button, then use the + and - buttons to cycle through the programs until you find your desired program.
- **Flash:** This button has no defined function for this unit.
- **Speed:** Sets program speed. Press this button, then use the + and - buttons to adjust program speed. Please note that this button is used in multiple operating modes.
- **+ and - buttons:** These two buttons cycle through available built-in programs, adjust color intensity, or adjust program speed, depending on currently selected operating mode.

PRIMARY-SECONDARY SET UP

This function allows you to link units together to run in a Primary-Secondary set-up, in which one unit will act as the controlling unit and the others will react to the controlling unit's built-in programs. Any unit can be configured to act as a Primary or as a Secondary, but only one unit in a given system can be programmed to act as the Primary.

Primary-Secondary Connections and Settings:

1. Daisy chain your units via the XLR connectors on the rear panels of each unit. Use standard XLR data cables to link your units together. Remember that the male XLR connector is the input and the female XLR connector is the output. The first unit in the chain (primary) will use the female XLR connector only. The last unit in the chain will use the male XLR connector only.
2. On the Primary unit, use the control panel and display screen to set the unit to the desired operating mode, just as you would if the unit were operating as a stand-alone device.
3. On each Secondary unit, use the control panel and display screen to navigate to the "Addr" option in the main menu. Simply leave the unit set to "Addr" to set the device as a Secondary unit.
4. The secondary units will now follow the behavior of the primary unit.

MULTI UNIT POWER LINKING

This feature allows you to connect the fixtures to one another using the power cable input and output sockets.

The maximum number of units that can be linked in this manner is 6 units. *DO NOT EXCEED THIS MAXIMUM NUMBER WHEN POWER LINKING UNITS!*

All linked units must be of the same make and model type. Do not mix and match units!

DMX SETUP

DMX-512: DMX is short for Digital Multiplex. This is a universal protocol used as a form of communication between intelligent fixtures and controllers. A DMX controller sends DMX data instructions from the controller to the fixture. DMX data is sent as serial data that travels from fixture to fixture via the DATA “IN” and DATA “OUT” XLR terminals located on all DMX fixtures (most controllers only have a DATA “OUT” terminal).

DMX Linking: DMX is a language allowing all makes and models of different manufacturers to be linked together and operate from a single controller, as long as all fixtures and the controller are DMX compliant. To ensure proper DMX data transmission, try to use the shortest cable path possible when linking several DMX fixtures. The order in which fixtures are connected in a DMX line does not influence the DMX addressing. For example, a fixture assigned a DMX address of 1 may be placed anywhere in a DMX line: at the beginning, at the end, or anywhere in the middle. When a fixture is assigned a DMX address of 1, the DMX controller knows to send DATA assigned to address 1 to that unit, no matter where it is located in the DMX chain.

Data Cable (DMX Cable) Requirements (For DMX Operation): This unit can be controlled via DMX-512 protocol. Your unit and your DMX controller require a 3-pin XLR connector for data input/output. We recommend Accu-Cable DMX cables. If you are making your own cables, be sure to use standard 110-120 Ohm shielded cable (This cable may be purchased at almost all pro lighting stores). Your cables should be made with a male and female XLR connector on either end of the cable. Also remember that DMX cable must be daisy chained and cannot be split.



Notice: Be sure to follow the figures below when making your own cables. Do not use the ground lug on the XLR connector. Do not connect the cable’s shield conductor to the ground lug or allow the shield conductor to come in contact with the XLR’s outer casing. Grounding the shield could cause a short circuit and erratic behavior.

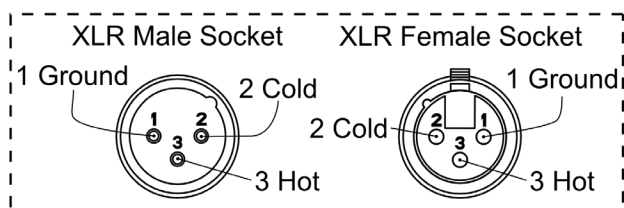

XLR Pin Configuration
Pin 1 = Ground
Pin 2 = Data Complement (negative)
Pin 3 = Data True (positive)

DMX SETUP

Special Note: Line Termination. When longer runs of cable are used, you may need to use a terminator on the last unit to avoid erratic behavior. A terminator is a 110-120 ohm 1/4 watt resistor which is connected between pins 2 and 3 of a male XLR connector (DATA + and DATA -). This unit is inserted in the female XLR connector of the last unit in your daisy chain to terminate the line. Using a cable terminator (ADJ part number Z-DMX/T) will decrease the possibilities of erratic behavior.

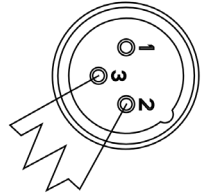

A DMX512 terminator reduces signal errors, avoiding most signal reflection interference. Connect PIN 2 (DMX-) and PIN 3 (DMX+) of the last fixture in series with a 120 Ohm, 1/4 W Resistor to terminate the DMX512.

5-Pin XLR DMX Connectors: Some manufacturers use 5-pin DMX-512 data cables for DATA transmission in place of 3-pin. 5-pin DMX fixtures may be integrated into a 3-pin DMX line with a 5-pin to 3-pin adapter cable. These adapters are available at most electric stores, or they may be assembled using the conversion chart below.

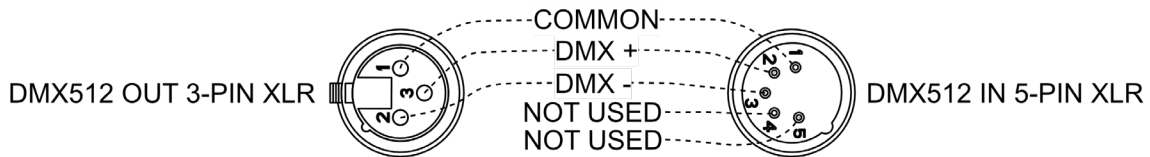

3-Pin XLR to 5-Pin XLR Conversion		
Ground/Shield	Pin 1	Pin 1
Data Compliment (- signal)	Pin 2	Pin 2
Data True (+ signal)	Pin 3	Pin 3
Not Used		Do Not Use
Not Used		Do Not Use

DMX SETUP

DMX ADDRESSING

All fixtures should be given a DMX starting address when operating with a DMX controller, in order to ensure that the correct fixture responds to the correct control signal. This digital starting address is the channel number from which the fixture starts to “listen” to the digital control signal sent out from the DMX controller. This starting DMX address is assigned by setting the correct DMX address on the digital control display on the fixture.

You can set the same starting address for all fixtures or a group of fixtures, or set different addresses for each individual fixture. Setting all fixtures to the same DMX address will cause all fixtures to react in the same way. In this case, please note that changing the settings of one channel will affect all the fixtures simultaneously.

If you set each fixture to a different DMX address, each unit will start to “listen” to the channel number you have set, based on the quantity of DMX channels of each fixture. That means changing the settings of one channel will only affect the selected fixture.

As an example, when operating this device in 3-channel mode, you should set the starting DMX address of the first unit to 1, the second unit to 4 (1 + 3), the third unit to 7 (1+ 3 + 3), and so on.

Channel Mode	Unit 1 Address	Unit 2 Address	Unit 3 Address	Unit 4 Address
3 Ch.	1	4	7	10
6 Ch.	1	7	13	19
10 Ch.	1	11	21	31
40 Ch.	1	41	81	121

DMX TRAITS

CHANNEL				DMX VALUES	FUNCTION
3CH	6CH	10CH	40CH		
	1	1		0 - 255	Red Color , 0% to 100%
	2	2		0 - 255	Green Color , 0% to 100%
	3	3		0 - 255	Blue Color , 0% to 100%
	4	4		0 - 255	White Color , 0% to 100%
	5	5		0 - 255	Amber Color , 0% to 100%
	6	6		0 - 255	UV Color , 0% to 100%
1		8	1		Auto Mode / Sound Control Mode
				0 - 9	No function
				10 - 17	Auto Mode 1
				18 - 25	Auto Mode 2
				26 - 33	Auto Mode 3
				34 - 41	Auto Mode 4
				42 - 49	Auto Mode 5
				50 - 57	Auto Mode 6
				58 - 65	Auto Mode 7
				66 - 73	Auto Mode 8
				74 - 81	Auto Mode 9
				82 - 89	Auto Mode 10
				90 - 97	Auto Mode 11
				98 - 105	Auto Mode 12
				106 - 113	Auto Mode 13
				114 - 121	Auto Mode 14
				122 - 129	Auto Mode 15
				130 - 137	Auto Mode 16
				138 - 145	Auto Mode 17
				146 - 153	Auto Mode 1 - 17 Cycling
				154 - 161	Sound Control Mode 1
162 - 169	Sound Control Mode 2				
170 - 177	Sound Control Mode 3				
178 - 185	Sound Control Mode 4				
186 - 193	Sound Control Mode 5				
194 - 201	Sound Control Mode 6				
202 - 209	Sound Control Mode 7				
210 - 217	Sound Control Mode 8				

CONTINUED ON NEXT PAGE

DMX TRAITS

CHANNEL				DMX VALUES	FUNCTION
3CH	6CH	10CH	40CH		
1		8	1		Auto Mode / Sound Control Mode (continued)
				218 - 225	Sound Control Mode 9
				226 - 233	Sound Control Mode 10
				234 - 241	Sound Control Mode 11
				242 - 255	Sound Control Mode 1 - 11 Cycling
2		9	2	0 - 255	Auto Mode Speed , slow to fast
3		10	3	0 - 255	Master Dimming , 0% to 100%
		7	4		Strobing
				0 - 9	Full On
				10 - 255	Strobe Speed, slow to fast
			5	0 - 255	Red Zone 1 , 0% to 100%
			6	0 - 255	Green Zone 1 , 0% to 100%
			7	0 - 255	Blue Zone 1 , 0% to 100%
			8	0 - 255	White Zone 1 , 0% to 100%
			9	0 - 255	Amber Zone 1 , 0% to 100%
			10	0 - 255	UV Zone 1 , 0% to 100%
			11	0 - 255	Red Zone 2 , 0% to 100%
			12	0 - 255	Green Zone 2 , 0% to 100%
			13	0 - 255	Blue Zone 2 , 0% to 100%
			14	0 - 255	White Zone 2 , 0% to 100%
			15	0 - 255	Amber Zone 2 , 0% to 100%
			16	0 - 255	UV Zone 2 , 0% to 100%
			17	0 - 255	Red Zone 3 , 0% to 100%
			18	0 - 255	Green Zone 3 , 0% to 100%
			19	0 - 255	Blue Zone 3 , 0% to 100%
			20	0 - 255	White Zone 3 , 0% to 100%
			21	0 - 255	Amber Zone 3 , 0% to 100%
			22	0 - 255	UV Zone 3 , 0% to 100%
			23	0 - 255	Red Zone 4 , 0% to 100%
			24	0 - 255	Green Zone 4 , 0% to 100%
			25	0 - 255	Blue Zone 4 , 0% to 100%
			26	0 - 255	White Zone 4 , 0% to 100%
			27	0 - 255	Amber Zone 4 , 0% to 100%
			28	0 - 255	UV Zone 4 , 0% to 100%
			29	0 - 255	Red Zone 5 , 0% to 100%
			30	0 - 255	Green Zone 5 , 0% to 100%
			31	0 - 255	Blue Zone 5 , 0% to 100%
			32	0 - 255	White Zone 5 , 0% to 100%

CONTINUED ON NEXT PAGE

DMX TRAITS

CHANNEL				DMX VALUES	FUNCTION
3CH	6CH	10CH	40CH		
			33	0 - 255	<i>Amber Zone 5</i> , 0% to 100%
			34	0 - 255	<i>UV Zone 5</i> , 0% to 100%
			35	0 - 255	<i>Red Zone 6</i> , 0% to 100%
			36	0 - 255	<i>Green Zone 6</i> , 0% to 100%
			37	0 - 255	<i>Blue Zone 6</i> , 0% to 100%
			38	0 - 255	<i>White Zone 6</i> , 0% to 100%
			39	0 - 255	<i>Amber Zone 6</i> , 0% to 100%
			40	0 - 255	<i>UV Zone 6</i> , 0% to 100%

CLEANING AND MAINTENANCE



DISCONNECT POWER BEFORE PERFORMING ANY CLEANING OR MAINTENANCE!

CLEANING

Frequent cleaning is recommended to ensure proper function, optimized light output, and an extended life. The frequency of cleaning depends on the environment in which the device operates: damp, smoky, or particularly dirty environments can cause greater accumulation of dirt on the fixture housing and/or light fixture optics. Clean the external surface and the front lens of the device periodically with a soft cloth to avoid dirt/debris accumulation.

NEVER use alcohol, solvents, or ammonia-based cleaners.

MAINTENANCE

Regular inspections are recommended to ensure proper function and extended life. There are no user serviceable parts inside these devices; please refer all other service issues to Eliminator Lighting. Should you need any spare parts, please order genuine parts from Eliminator Lighting.

Please refer to the following points during routine inspections:

- A detailed review should be performed by an approved electrical engineer every three months, to make sure the circuit contacts are in good condition in order to prevent overheating.
- Be sure all screws and fasteners are securely tightened at all times. Loose screws may fall out during normal operation, resulting in damage or injury as larger parts could fall.
- Check for any deformations on the unit. Deformations could allow for dust to enter into the device, or cause the device to fall and seriously injure a person(s).
- Electric power supply cables must not show any damage, material fatigue, or sediments.

FUSE REPLACEMENT

This device features a replaceable fuse located alongside the Power Input on the back side of the device. To access the fuse, use a flat head screwdriver to catch the groove in the wall of the Power Input. **BE CAREFUL NOT TO DAMAGE THE FUSE CLIP, THE POWER INPUT, OR THE PRONGS.** When replacing the fuse, be sure to replace the correct one, as the fuse clip contains both an operational fuse and a spare fuse. **Replace the fuse only with an identical F5A 250V fuse.**

SPECIFICATIONS

- Input voltage :100V-250V/50-60 HZ
- Power supply: 250W
- Fuse rating: F5A / 250V
- Source: 24 x 6-in-1 10W RGBWA+UV LED lamps
- Control: DMX / Sound controller / Auto mode/ Primary-Secondary Mode
- Display: 4 buttons LED display
- DMX channel modes: 3CH / 6CH / 10CH / 40CH
- Connection: 3pin Data in/out
- Material: Steel
- DC fan cooledx2
- IEC Power input/output
- 25° beam angle
- Product dimensions: 12.2" x 8.9" x 10.7" / 310mm x 226mm x 273mm
- Weight: 7.9 lbs / 3.6 kgs

DIMENSIONAL DRAWINGS

12.2in (310mm)

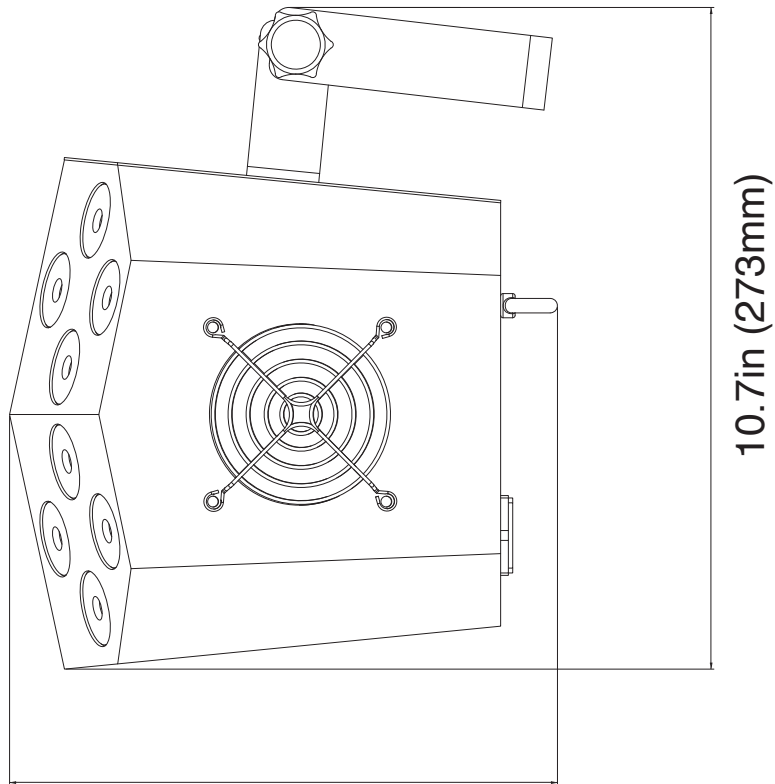
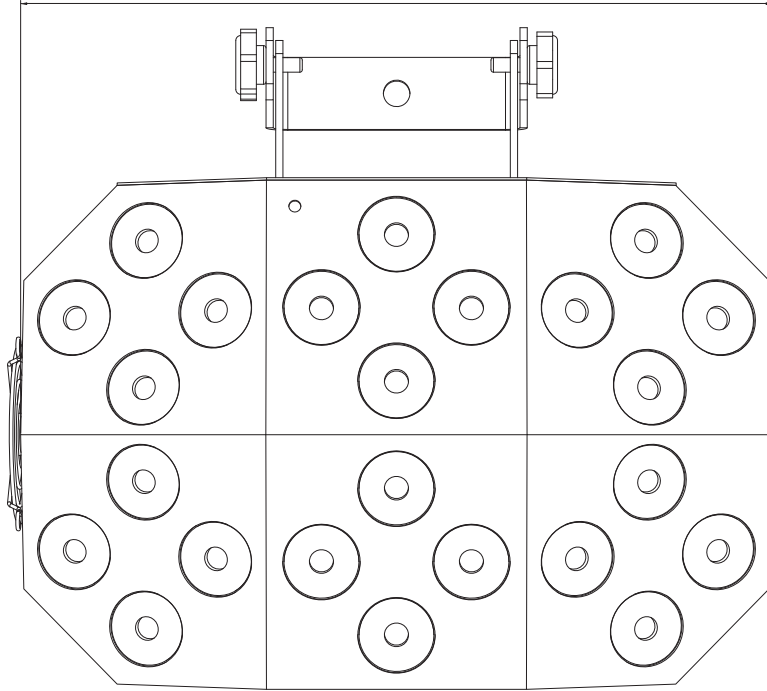

8.9in (226mm)

10.7in (273mm)

This page intentionally left blank.

